

groov 2–16 VAC VDC INPUT MODULES

Features

- > 24 channels per module
- > Module cover with LED indicates module status
- > Touch-sensitive pad triggers display of module information on *groov* EPIC® processor's display
- > Operating temperature: -20 to 70 °C
- > UL Hazardous Locations approved and ATEX compliant
- > Guaranteed for life



GRV-IACDCTTL-24 module

DESCRIPTION

groov I/O modules are part of the *groov* EPIC® (Edge Programmable Industrial Controller) system. Wired directly to field devices (sensors and actuators), *groov* I/O translates the electrical signals from those devices into the digital language computers understand—so you can monitor and control devices and use their data wherever you need it, in your local computer network or in cloud services.

groov 2–16 VAC/VDC input modules are used to sense the on or off status for AC or DC devices between 2–16 V. These modules are specifically designed to accommodate logic level signals. They can sense status from up to 24 devices. This module does not offer channel-to-channel isolation. Note that all channels share a common reference terminal.

Choose the module you need based on your requirements:

The **GRV-IACDCTTL-24** offers a full set of features, including on/off state, latching, counting, and totalization; and frequency, period, and pulse measurement.

The **GRV-IACDCTTLS-24** module provides input state only, offering a lower cost option for projects that require only point states.

See "[Features and Specifications](#)" on page 2 for additional differences.

Wiring is simplified with a top-mounted connector, which provides spring-clamp terminals for power, common, and field wiring. The connector is held in place by a single, captive retention screw but can be removed with the field wiring intact for wiring in advance or easier module field replacement.

A swinging, two-position cover protects wiring from inadvertent contact, as does the dead-front design. The two positions of the cover offer the option of more space to accommodate larger wire. The module cover provides a touch-sensitive pad; touch the pad and the

groov EPIC processor displays information about the module, including specifications and a wiring diagram.

The module pivots into place and is held securely in place by a captive retention screw.

groov I/O modules are hot swappable (which means they can be installed or removed without turning off power to the unit) and self-identifying—as soon as you mount the module to the chassis, it communicates to the processor and identifies itself.

Each *groov* I/O module cover provides a large module LED to indicate module health at a glance.

All *groov* power supplies, voltage converters, pass-through power adapters, I/O modules, and processors are UL/cUL listed and compliant with the ATEX, Low Voltage, and EMC CE directives. Each module is factory tested twice before shipment and most modules are guaranteed for life.



Part Numbers

Part	Description
GRV-IACDCTTL-24	AC/DC input, 24 channels, 2–16 V AC/DC
GRV-IACDCTTLS-24	AC/DC input, 24 channels, 2–16 V AC/DC, on/off state only



FEATURES AND SPECIFICATIONS

Features

Feature	GRV-IACDCTTL-24	GRV-IACDCTTLS-24
Number of channels	24	24
On/off state	x	x
On/off latching	x	
Counting	x	
On/off totalization	x	
Frequency measurement	x	
Period measurement	x	
Pulse measurement	x	

Specifications

Specification	GRV-IACDCTTL-24	GRV-IACDCTTLS-24
Input Voltage ^a	2–16 VAC / VDC	2–16 VAC / VDC
Turn-on Voltage	2.0 VAC (Peak) / VDC	2.0 VAC (peak) / VDC
Turn-off Voltage	0.8 VAC (Peak) / VDC	0.8 VAC (Peak) / VDC
Input Impedance ($\pm 5\%$)	2 kOhms	2 kOhms
Max. Freq. (50% square wave 5 V _{p-p})	2000 Hz	N/A
IEC Input Type	N/A	N/A
Isolation (field-to-logic)	300 V working, 1500 V transient (1 minute)	300 V working, 1500 V transient (1 minute)
Isolation (channel-to-channel)	None	None
Number of Channels	24	24
Chassis Power Consumption	1.0 W	1.0 W
Minimum GRV-EPIC-PR1 Firmware Version	1.0.0	1.0.0
Minimum PAC Project Version	10.0000	10.0000
Wire Size	28–14 AWG	28–14 AWG
Torque, connector screw	2.5 in-lb (0.28 N-m)	2.5 in-lb (0.28 N-m)
Torque, hold-down screw	3.5 in-lb (0.4 N-m)	3.5 in-lb (0.4 N-m)
Temperature (operating)	-20 °C to +70 °C	-20 °C to +70 °C
Temperature (storage)	-40 °C to +85 °C	-40 °C to +85 °C
Relative Humidity (non-condensing)	5–95%	5–95%
Agency Approvals	UL/cUL(Class 1 Div. 2); CE, ATEX(Category 3, Zone 2), RoHS; DFARS; CB Scheme	
Warranty	Lifetime	Lifetime

- a. The GRV-IACDCTTL-24 is primarily intended for use as a polarity-insensitive low voltage DC input module. It can be used with AC input voltages by reading the On Latch or Off Latch when discrete input latching is enabled. This also applies when using the various features other than state and latches.



MOUNTING

Mount *groov* I/O modules onto a *groov* EPIC chassis. See [groov EPIC Chassis Data Sheet](#) (form 2247). You may also want to review the

diagrams in the Description of Module Parts section so you learn the names of the various parts of the module.

Installing the module

The numbers on the diagrams correspond to the numbered steps in these instructions.

CAUTION: For electrical safety, turn off power to the chassis and de-energize field devices wired to the terminal connector before starting.

1. Orient the *groov* EPIC chassis so that the module connector numbers are right-side up, with module connector zero on the left, as shown in the diagram.
2. Hold the module at a 45° angle, lining up the alignment tab on the back tip of the module with the slot at the back of the chassis.
3. Pivot the front of the module down to the module connector on the chassis. Push to snap the module into the connector.
4. Swing the module cover up so you can access the module retention screw. Secure the module into position by tightening the module retention screw.

CAUTION: Do not over-tighten. See the torque specs in the Specifications table.

5. If the module does not have a terminal connector, install one.
6. Secure the terminal connector by tightening the terminal connector screw.

CAUTION: Do not over-tighten. See the torque specs in the Specifications table.

7. Follow the wiring instructions in the Pinout and Wiring section to wire your field devices to the channels on the terminal connector.
8. When wiring is complete, swing the module cover back down to cover the wires. If the wires are too thick to close the module cover easily, lift the module cover, then raise the back of the module cover up to the higher position. Swing the module cover back down to cover the wires.

When you are done installing modules and wiring, if you powered down your unit, you can turn it back on.

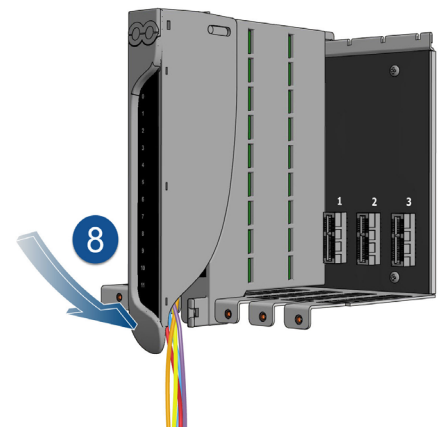
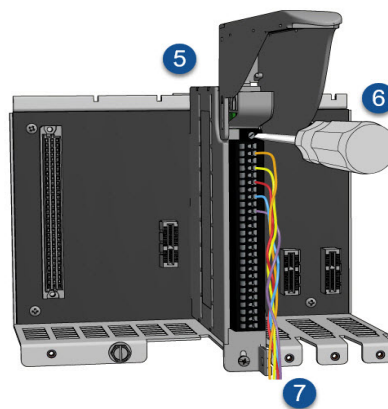
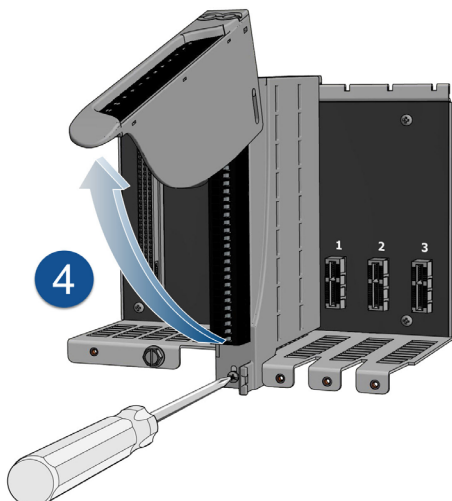
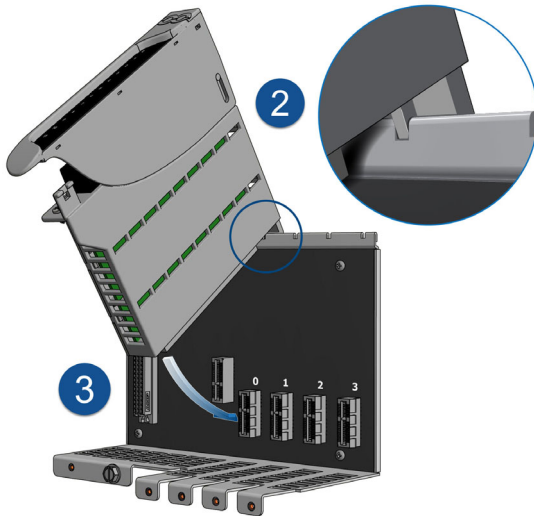
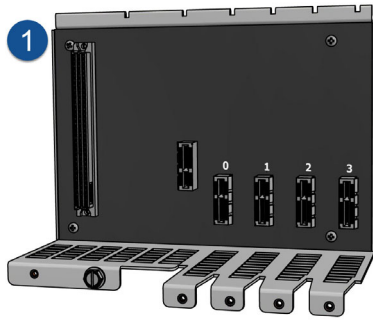

Removing the module

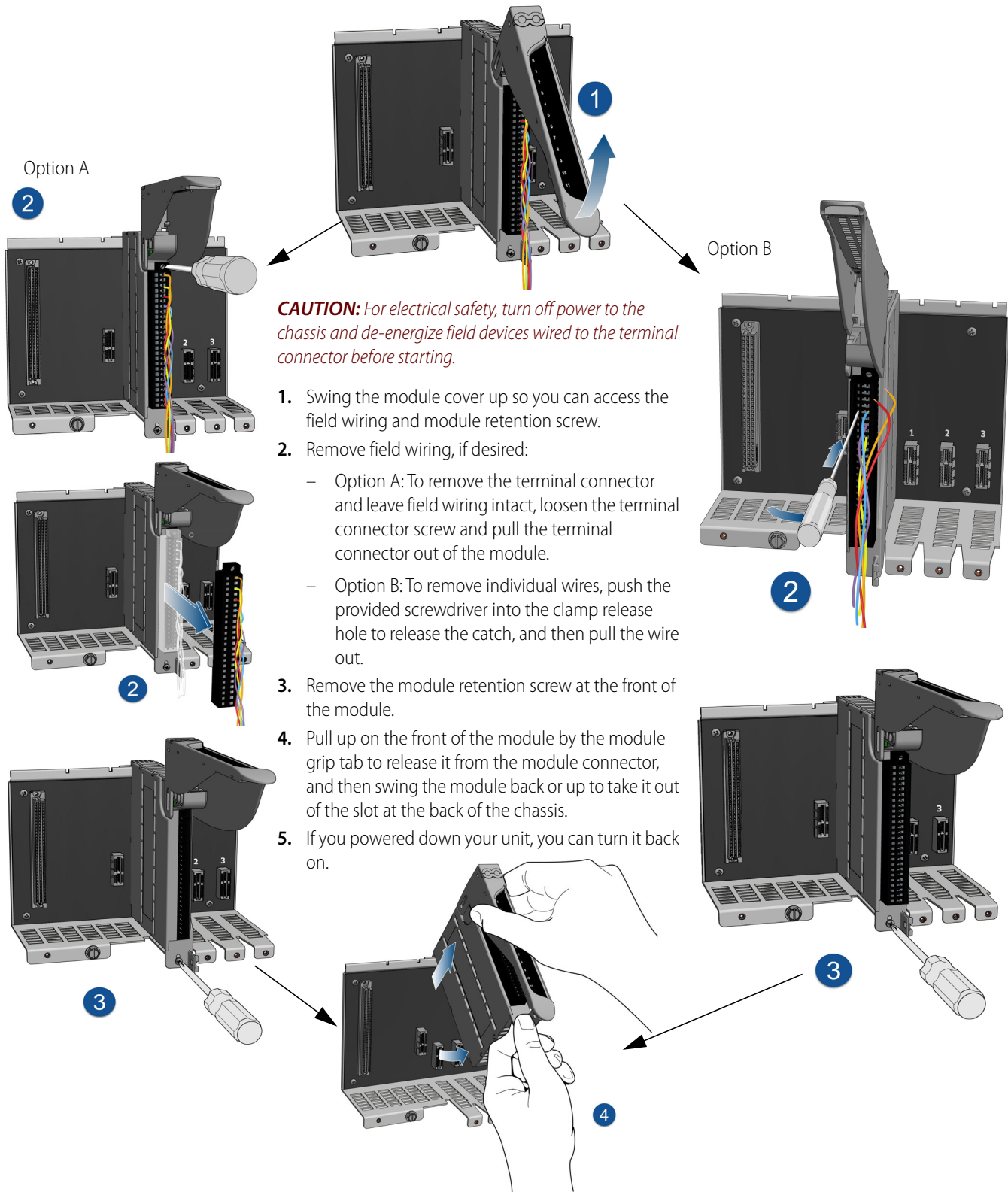

PINOUT AND WIRING

Before you begin wiring, do the following tasks:

CAUTION: For electrical safety, turn off power to the chassis and de-energize field devices wired to the terminal connector before starting.

Select the appropriate wire. The terminal connectors are rated for 28–14 AWG wire. If you're using stranded wire, you can make an easier and better connection by tinning the strands or adding ferrules.

Ensure that you have the screwdriver supplied with your module.

If you are unfamiliar with the names of some of the parts of the module, review the diagrams on this page and in the Description of Module Parts section.

It may be easier to insert wires if you remove the terminal connector from the module. To remove the terminal connector, loosen the terminal connector screw at one end of the connector, then pull the connector straight out to remove it from the module.

If you have never used a spring-clamp wiring system, take a moment to familiarize yourself with the diagram below. The clamp release hole is where you will insert the screwdriver. The field wiring hole is where you will insert your field wires.

If you look into the field wiring hole, you will see a highly reflective surface. If you can see that surface, that means that the clamp is closed.

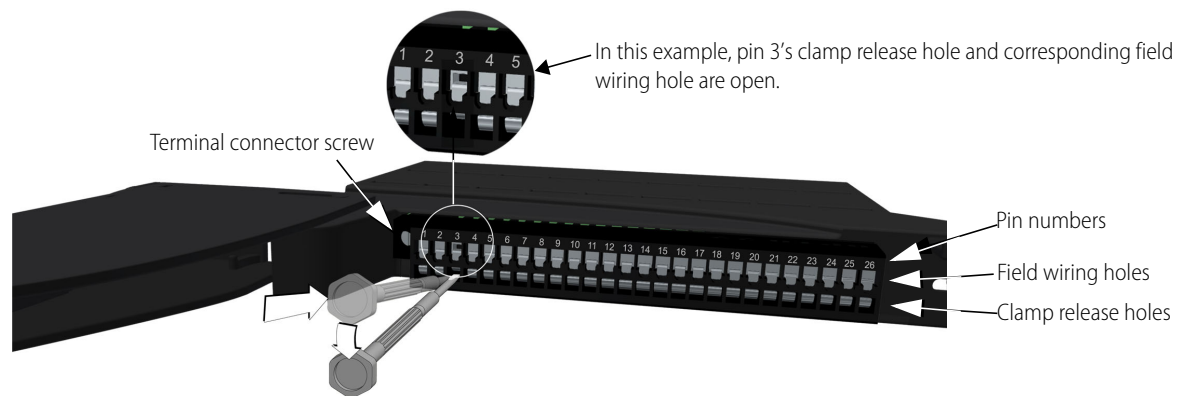

Follow these instructions to connect your field wires to the module:

CAUTION: For electrical safety, turn off power to the chassis and de-energize field devices wired to the terminal connector before starting.

1. Orient the module or terminal connector to match the wiring diagrams on the following page. To make it easier to handle the screwdriver and the field wires, secure the module by doing one of the following:
 - If you are working with the terminal connector while it is attached to the module, make sure the module is screwed securely to the chassis.
 - If you are working only with the terminal connector, secure the terminal connector with a clamp.
2. Hold the screwdriver so that you can place the flat side of the blade against the left side of the clamp release hole.
3. Slide the screwdriver into the clamp release hole, along the left side, until you feel the blade begin to meet some resistance. Gently push the screwdriver in a little more, until you feel the screwdriver stop.

Note: If you push in too hard, the screwdriver might pop out of the clamp release hole and you'll have to return to step 2.

- Look into the field wiring hole. If it is dark, the clamp is open. You can go to the next step.
 - If you can still see the highly reflective surface, gently pull the screwdriver handle to the left until you feel the blade stop. Hold the screwdriver in that position. Look into the field wiring hole. If it is dark, the clamp is open. You can go to the next step.
4. Insert the wire into the field wiring hole until it meets complete resistance. Then pull out the screwdriver.
 5. Test that the wire is secure by gently pulling on it. If the wire pulls out, repeat steps 2 through 4.

To remove a wire, push the screwdriver into the clamp release hole as described in steps 2 and 3 above, and then pull the wire out.

WIRING: GRV-IACDCTTL-24, GRV-IACDCTTLS-24

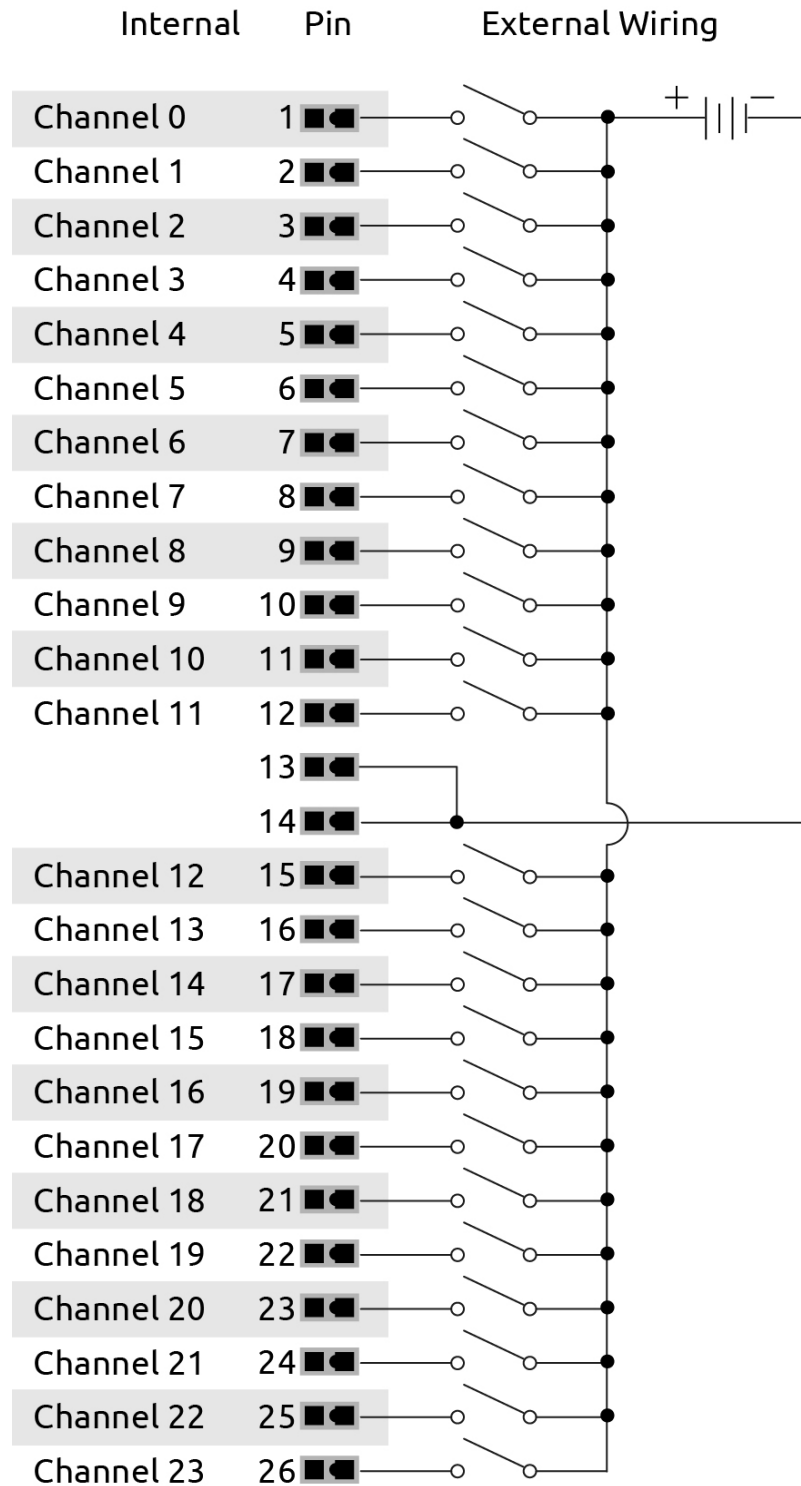

DIMENSIONS: GRV-IACDCTTL-24, GRV-IACDCTTLS-24

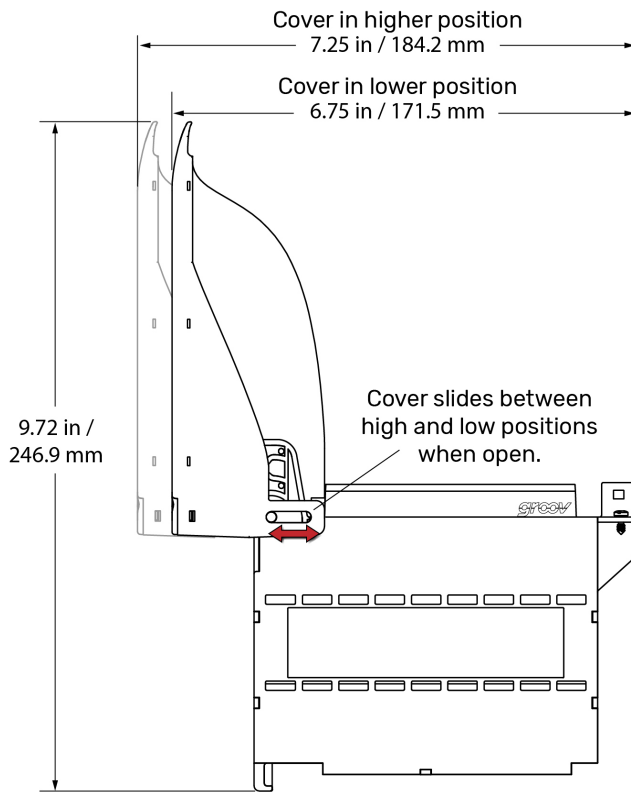

The module cover pivots and can be adjusted to two different heights (positions). The higher position provides more space to accommodate thicker wires.

To switch between higher and lower position, open the cover to at least a 45° angle. Grasp the hinged end of the module cover and do one of the following:

- Pull up on the back hinge to slide it to the higher position.

- Push down on the back hinge to slide it to the lower position.

You cannot switch between the higher and lower positions while the cover is closed.

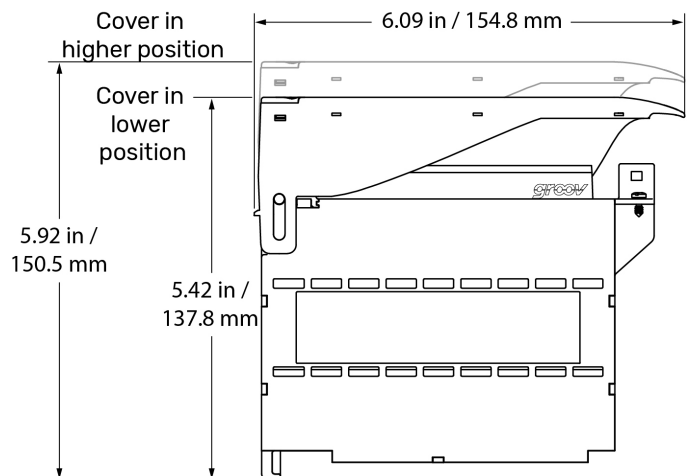
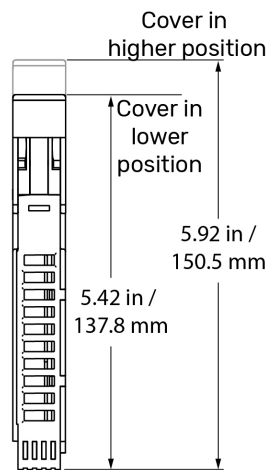

DIMENSIONS: GRV-IACDCTTL-24, GRV-IACDCTTLS-24

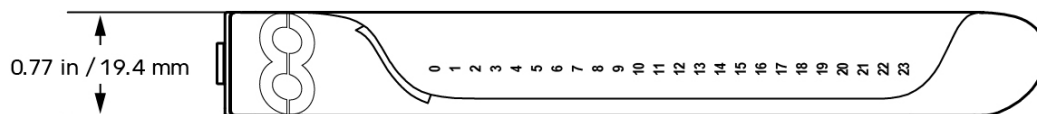

DESCRIPTION OF MODULE PARTS

The following diagram identifies the parts of the modules. The installation instructions in the documentation rely on these terms to describe how to handle the module.

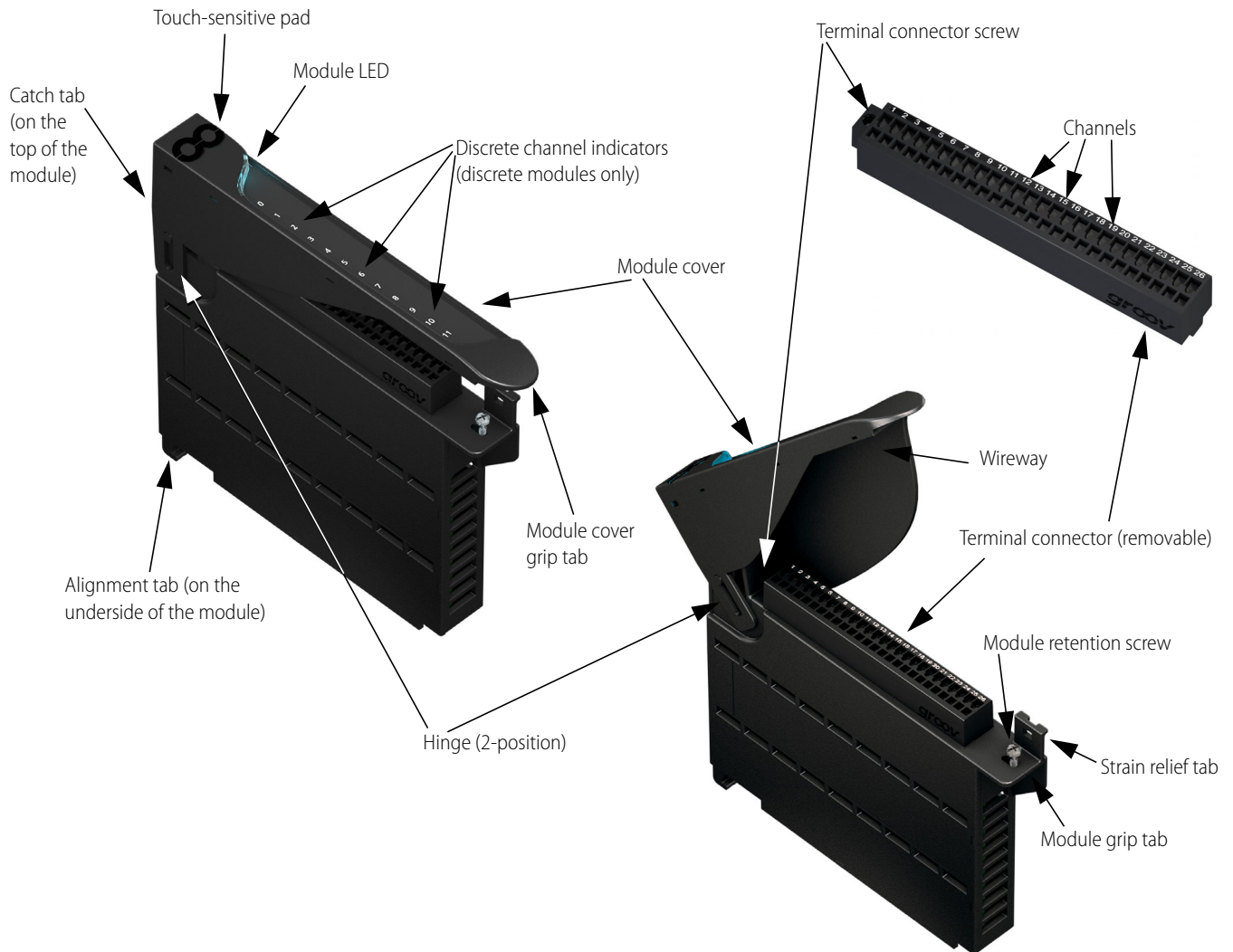

Some parts offer unique features:

Module LED: Provides a visual indication of the health of the module. For example, if it is blue, the module is operating normally. If it is blinking blue, the module's information is being displayed on the *groov* EPIC processor's screen. For a complete list of the various colors that this LED might display, see the [groov EPIC User's Guide](#) (form 2267).

Terminal connector: Specially designed for *groov* I/O modules, it provides a spring-clamp wiring system to securely connect the wires from your field devices to the module. To learn how to use a spring-clamp wiring system, see the Pinouts and Wiring section.

Hinge and Wireway: These two features work together to provide more space for wires. The hinge can be adjusted between a lower position and a higher position. The wireway is the space underneath the module cover. To increase this space, you can raise the hinge to the higher position.

Touch-sensitive pad: Offers a convenient way to display the module's information on the *groov* EPIC processor. Press on the pad for approximately two seconds and the processor displays that module's information on the screen, as well as changing the module LED to a blinking blue light.



Catch tab: Located at the top of the module, the catch tab provides a place for the cover to “catch” or stop. This prevents the cover from closing so that you can work on attaching or detaching wires to the terminal connector.

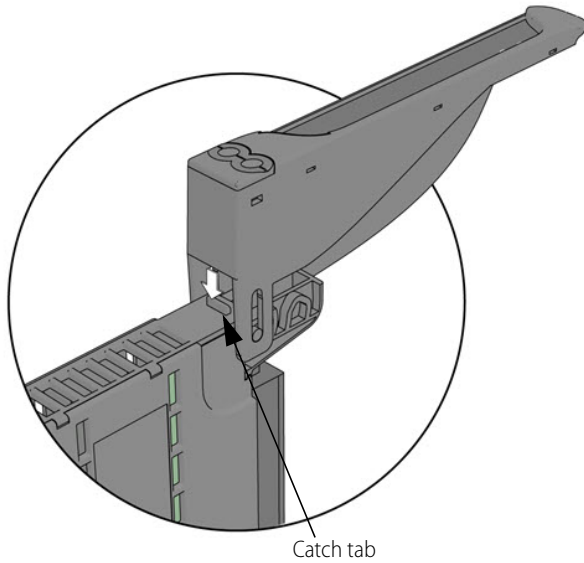

Strain relief tab: This tab offers a way to collect wires into a bundle and secure them to the module. Attaching the wires to the strain relief tab can help hold the wires in a semi-fixed position, preventing them from interfering while you work on a nearby module. It also prevents strain on the part of the wire attached to the terminal connector.

Collect the wires into a bundle, pull a zip tie through the hole in the tab, wrap the zip tie around the bundle and tab, then clip the excess zip tie.

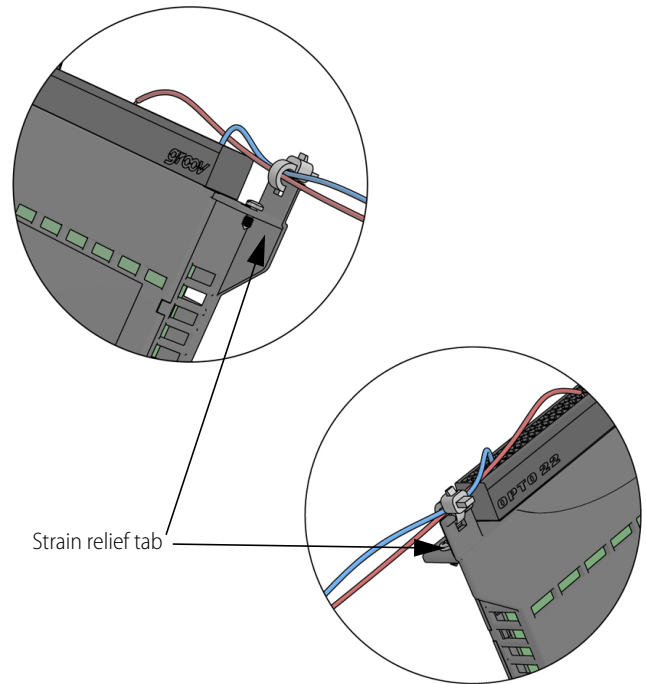

PRODUCTS

Opto 22 develops and manufactures reliable, easy-to-use, open standards-based hardware and software products.

Industrial automation, process control, building automation, industrial refrigeration, remote monitoring, data acquisition, and industrial internet of things (IIoT) applications worldwide all rely on Opto 22.

groov EPIC® System

Opto 22's *groov* Edge Programmable Industrial Controller (EPIC) system is the culmination of over 40 years of experience in designing products for the automation industry.

groov EPIC gives you an industrially hardened system with guaranteed-for-life I/O, a flexible Linux®-based processor with gateway functions, and software that meets the needs of your automation and IIoT applications.

groov EPIC I/O

I/O provides the local connection to sensors and equipment. *groov* I/O offers up to 24 channels on each I/O module, with a spring-clamp terminal strip, integrated wireway, swing-away cover, and LEDs indicating module health and digital channel status.

groov I/O is hot swappable, UL Hazardous Locations approved, and ATEX compliant. Opto 22 I/O is so reliable, we guarantee it for life.

groov EPIC Processor

The heart of the system is the *groov* EPIC processor. It handles a wide range of digital, analog, and serial functions for data collection, remote monitoring, process control, and discrete and hybrid manufacturing.

In addition, the EPIC provides secure data communications among physical assets, control systems, software applications, online services, and more, both on premises and in the cloud.

Configuring and troubleshooting I/O and networking is easier with the EPIC's integrated high-resolution color touchscreen. Authorized users can manage the system locally on the touchscreen or on a monitor connected via the HDMI or USB ports.

groov EPIC Software

Software included in the *groov* EPIC controller:

- PAC Control engine to run PAC Control strategies and PAC Display projects
- CODESYS Runtime engine to run IEC61131-3 compliant programs built with CODESYS Development System

Optional access to the Linux operating system through a secure shell (SSH) to download and run custom applications

groov View for building your own device-independent HMI, viewable on the touchscreen, PCs, and mobile devices.

Node-RED for creating simple logic flows from pre-built nodes
Ignition Edge® from Inductive Automation®, with OPC-UA drivers to Allen-Bradley®, Siemens®, and other control systems, and MQTT/Sparkplug communications for efficient IIoT data transfer

Older products

From solid state relays (our first products) to world-famous G4 and SNAP I/O, to SNAP PAC controllers, older Opto 22 products are still supported and still doing the job at thousands of installations worldwide. You can count on us to give you the reliability and service you expect, now and in the future.



QUALITY

Founded in 1974, Opto 22 has established a worldwide reputation for high-quality products. All are made in the U.S.A. at our manufacturing facility in Temecula, California.

Because we test each product twice before it leaves our factory rather than testing a sample of each batch, we can afford to guarantee most solid-state relays and optically isolated I/O modules for life.

